

History Record

Date	Part No.	SPEC No.	Description.	Remarks.
	<u>ZTB503F58-EN</u>			
<div style="background-color: #90EE90; padding: 2px; font-size: 8px;"> RoHS Compliant Lead free Lead-free soldering </div>	ISO9001:2000 ISO14001:2004	Approved by	Check by	Design by
		May-15-2007	May-10-2005	Jan-16-1999
Reversions	Total Page	<i>Xu gang dong</i>	<i>Liu jun</i>	<i>Wang hon</i>
CR-002HDIP				

SPECIFICATION

1 SCOPE

This specification shall cover the characteristics of the ceramic resonator with the type ZTB503F58CAC0-B0.

2 PART NO.

PART NUMBER	PREVIOUS PART NUMBER
ZTB503F58	ZTB503F58
CUSTOMER PART NO	SPECIFICATION NO

3 OUTLINE DRAWING AND DIMENSIONS

3.1 Appearance: No visible damage and dirt.

3.2 Construction: Leads are fixed on electrode and body is enclosure packaged by plastic shell and resin.

3.3 The products conform to the RoHS directive and nation environmental protection law.

3.4 Dimensions

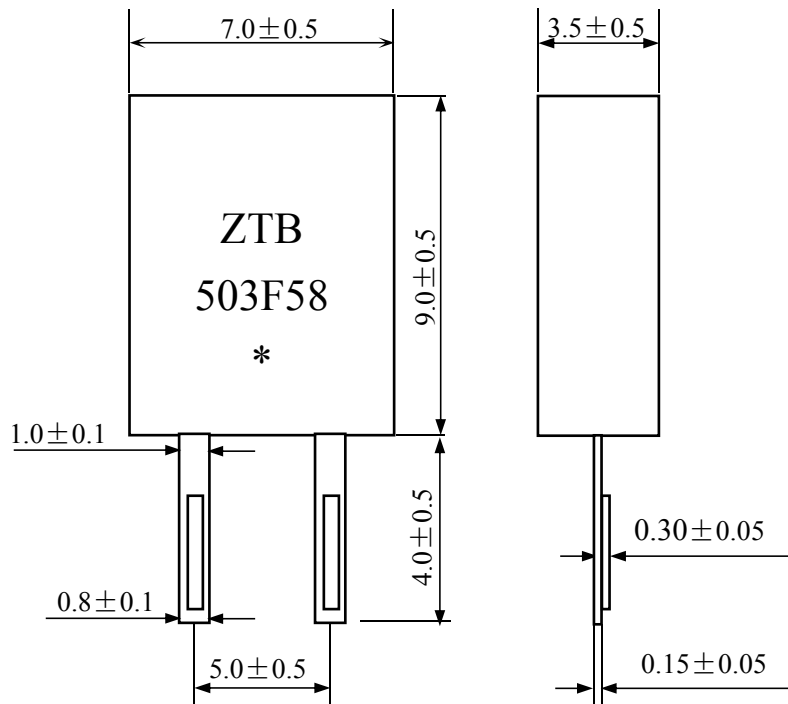

*:EIAJ MONTHLY CODE

4 RATING AND ELECTRICAL SPECIFICATIONS

4.1 RATING

Items	Content
Withstanding Voltage (V)	50 (DC, 1min)
Insulation Resistance Ri, (MΩ) min.	100 (10V, 1min)
Operating Temperature Range (°C)	-25~+85
Storage Temperature Range (°C)	-40~+85
Rating Voltage UR (V) max.	6V DC
	15V p-p

4.2 ELECTRICAL SPECIFICATIONS

Items	Content
Anti-Resonant Frequency Fa (kHz)	514.0±2.0
Resonant Impedance Ro (Ω) max	20
Electrostatic Capacitance (pF)	550(1±20%)
Band width (fa-fr) kHz min	38
Temperature Coefficient of Resonant Frequency (%) max	±0.3 (Resonant Frequency drift, -25°C~+85°C)
Oscillation Frequency Aging Rate (10years) (%) max *	±0.3 (From initial value)

*Components shall be left in a chamber of +85 ± 2 °C for 1000 hours, then measured after leaving in natural condition for 1 hour.

5 MEASUREMENTS

5.1 Measurement Conditions

Parts shall be measured under a condition (Temp. : 20 °C ±15 °C ,Humidity : 65%±20% R.H.) unless the standard condition(Temp. : 25 °C ±3 °C ,Humidity : 65%±5% R.H.) is regulated to measure.

5.2 Test Circuit

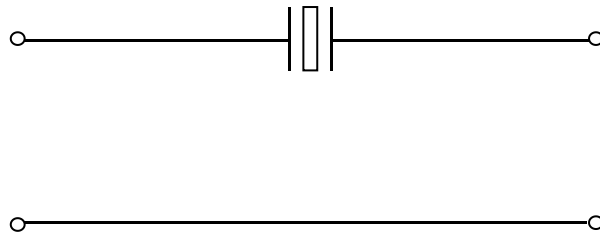

6 PHYSICAL AND ENVIRONMENTAL CHARACTERISTICS

No.	Item	Condition of Test	Performance Requirement
6.1	Humidity	Subject the resonator at 40 ± 2 °C and 90%-95% R.H. for 96 h, resonators shall be measured after being placed in natural conditions for 1h.	It shall fulfill Table 1.

6.2	High Temperature Exposure	Subject the resonator to $85 \pm 2^\circ\text{C}$ for 96h, resonator shall be measured after being placed in natural conditions for 1h.	It shall fulfill Table 1.	
6.3	Low Temperature Exposure	Subject the resonator to $-40 \pm 2^\circ\text{C}$ for 96h, resonator shall be measured after being placed in natural conditions for 1h.	It shall fulfill Table 1.	
6.4	Temperature Cycling	After temperature cycling of blow table was performed 5 times, Filter shall be measured after being placed in natural conditions for 1h.	It shall fulfill Table 1.	
		Temperature		Time
		$-25 \pm 3^\circ\text{C}$		30 ± 3 min
		$85 \pm 3^\circ\text{C}$	30 ± 3 min	
6.5	Vibration	Subject the resonator to vibration for 2h. Each in x y and z axis with the amplitude of 1.5mm, The frequency shall be varied uniformly between the limits of 10Hz-55Hz-10Hz and then resonator shall be measured.	It shall fulfill Table 1.	
6.6	Mechanical Shock	Resonator shall be measured after 3 times random dropping from the height of 70cm on concrete floor.	No visible damage and it shall fulfill Table 1.	
6.7	Resistance to Soldering Heat	Lead terminals are immersed up to 2 mm from filter's body in soldering bath of $260^\circ\text{C} \pm 5^\circ\text{C}$ for $10\text{s} \pm 1\text{s}$ and then resonator shall be measured after being placed in natural conditions for 1h.	It shall fulfill Table 1.	
6.8	Solderability	Lead terminals are immersed up to 2mm from filter's body in soldering bath of $250^\circ\text{C} \pm 5^\circ\text{C}$ for $3\text{s} \pm 0.5\text{s}$.	More than 95% of the terminal surface of the filter shall be covered with fresh solder.	

6. ENVIRONMENTAL TEST

No.	Item	Condition of Test	Performance Requirements
6.9	Terminal Strength	Force of 5N is applied to each lead in axial direction for $10\text{s} \pm 1\text{s}$.	No visible damage and it shall fulfill Table 1.
6.9.1	Terminal Pulling	When force of 5N is applied to each lead in axial direction, the lead shall folded up 90° from the axial direction and folded back to the axial direction. The speed of folding shall be each 3s.	
6.9.2	Terminal Bending		

Table 1

Item	Specification after test
Resonant Frequency Change $\Delta Fr/Fr$ (%) max	± 0.3
Resonant Resistance (Ω)max	20
Static Capacitance(pF)	500(1 \pm 20%)
The limits in the above table are referenced to the initial measurements.	

7. PACKAGE

To protect the products in storage and transportation, it is necessary to pack them (outer and inner package). On paper pack, the following requirements are requested.

7.1 Dimensions and Mark

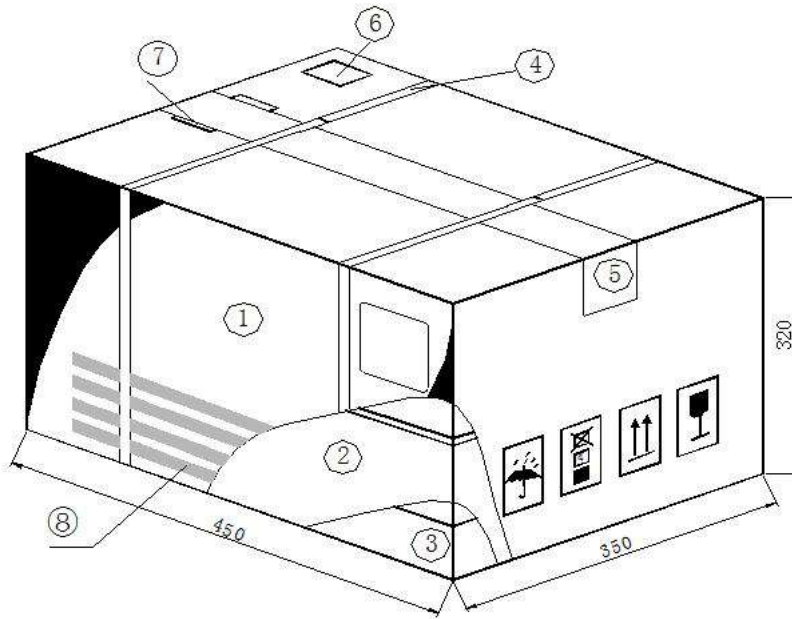

NO.	Name	Quantity
①	Package	1
②	Box	2
③	Inner Box	40
④	Belt	2.9 m
⑤	Adhesive tape	1.2 m
⑥	Label	1
⑦	Certificate of approval	1
⑧	Company name ,Address etc.	

7.2 Section of Package

Package is made of corrugated paper with thickness of 0.8cm. Package has 2 boxes, each has 20 inner boxes.

7.3 Quantity of Package

- Per plastic bag 500 pieces
- Per inner box 2 plastic bag

Per package 40 inner boxes
 (40000 pieces of piezoelectric ceramic part)

7.4 Inner Package

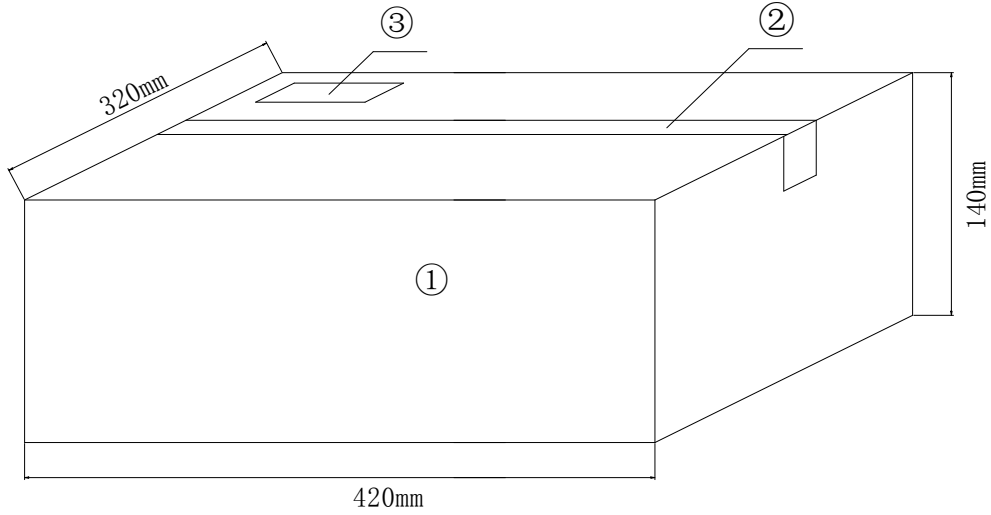

NO.	Name	Quantity
①	Inner package	1
②	Adhesive tape	1.2 m
③	Label	1

7.5 Inner Box Dimensions

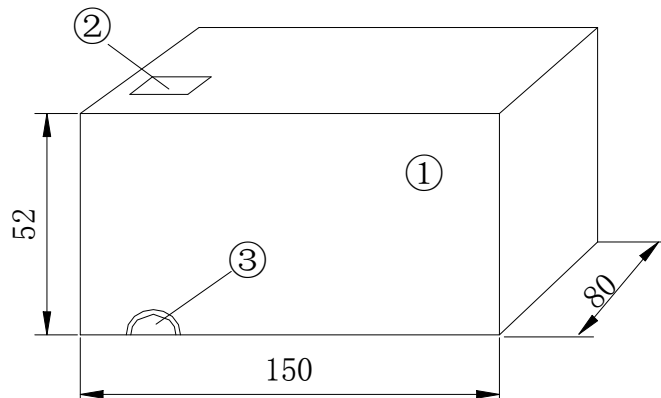

NO.	Name	Quantity
①	Inner Box	1
②	Label	1
③	QC Label	1

8. EIAJ Monthly Code

2011/2013/2015/2017		2012/2014/2016/2018	
MONTH	CODE	MONTH	CODE
JAN	A	JAN	N
FEB	B	FEB	P
MAR	C	MAR	Q
APR	D	APR	R
MAY	E	MAY	S
JUN	F	JUN	T
JUL	G	JUL	U
AUG	H	AUG	V
SEP	J	SEP	W
OCT	K	OCT	X
NOV	L	NOV	Y
DEC	M	DEC	Z

9. OTHER

9.1 Caution

9.1.1 Don't apply excess mechanical stress to the component and terminals at soldering. Do not use this product with bend.

9.1.2 Do not clean or wash the component for it is not hermetically sealed.

8.1.3 Do not use strong acidity flux , more than 0.2wt% chlorine content , in flow soldering.

9.1.4 Don't be close to fire.

9.1.5 All kinds of re-flow soldering must not be applied on the component.

9.1.6 This specification mentions the quality of the component as a single unit. Please insure the component is thoroughly evaluated in your application circuit

9.1.7 Expire date (Shelf life) of the products is six months after delivery under the conditions of a sealed and an unopened package. Please use the products within six months after delivery. If you store the products for a long time (more than six months), use carefully because the products may be degraded in the solderability or rusty. Please confirm solderability and characteristics for the products regularly.

9.1.8 Please contact us before using the product as automobile electronic component.

9.2 Notice

9.2.1 Please return one of this specification after your signature of acceptance.

9.2.2 When something gets doubtful with this specifications, we shall jointly work to get an agreement.